

Light EFX-16



User's Guide

High Current version
RESISTORS REQUIRED!

Document Version 1.3
7/31/2024

LOGIC RAILTM
TECHNOLOGIES

21175 Tomball Parkway Suite 287 Houston, TX 77070
(281) 251-5813 info@logicrailtech.com
<https://www.logicrailtech.com>

© 2023-24 Logic Rail Technologies All Rights Reserved
Printed in USA

Just Plug[®] is a Registered Trademark of Woodland Scenics

TABLE OF CONTENTS

1. Overview	2
1.1 Package Contents	2
1.2 Power Requirements	3
1.3 Board Callouts	3
1.4 Definition of Terms	4
1.5 Lighting Effect Definitions	4
1.6 Master On/Off Switch	7
2. Outputs and LED wiring	8
2.1 Basic LED connections	8
2.2 Multiple LEDs on one output	9
2.3 Special light situations	10
3. Connecting to DCC or LCC	12
4. Power methods	14
5. Configuring the <i>Light EFX-16</i> using DCC	15
5.1 Addressing the Light EFX-16	16
5.2 Definition of Configuration Variables (CVs)	18
5.3 Alternate Method for Configuring DCC Accessory Addresses	21
5.4 Using JMRI DecoderPro	21
5.5 Simple Time-based Control	22
6. Using JMRI PanelPro + LCC with the <i>Light EFX-16</i>	23
6.1 OpenLCB Network Tree	24
6.2 Light EFX-16 Identification and Naming	25
6.3 Configuration: name, brightness, and effect	25
6.4 Configuration: DCC Accessory Address, Auto-Off Timer	28
6.5 Configuration: input behavior	29
6.6 Extra Commands	30
6.7 Global configuration	32
6.8 Measurements	32
6.9 Restore to Factory Defaults	32
7. Special light examples	33
7.1 Traffic signals (DCC or LCC)	33
7.2 Photographer flash (DCC or LCC)	33
7.3 TV simulation (DCC or LCC)	34
7.4 Welding (DCC or LCC)	34
7.5 Fusee (DCC or LCC)	34
7.6 Chase lights (DCC or LCC)	35

- 7.7 Grade crossing logic (LCC only)..... 36
- 8. Mounting the *Light EFX-16*..... 37**
- 9. Updating the firmware 37**
- 10. Warranty, Repair and Troubleshooting 38**
 - 10.1 Warranty 38
 - 10.2 Repair 38
 - 10.3 Troubleshooting 39
- 11. Technical Support 39**

1. Overview

Thank you for purchasing a *Logic Rail Technologies* product.

The *Light EFX-16* provides model railroad on-layout lighting effects for 16 Just Plug®-compatible outputs. Each output is highly programmable through either a DCC (Digital Command Control) or LCC (Layout Command Control) connection. Using LCC to configure the *Light EFX-16* will enable substantially more capabilities than configuring it with DCC. Once configured, the board can operate via DCC or LCC, or standalone with a DC or AC power input.

Feature highlights include:

- Up to 250mA provided on each output; maximum of 1.8A per board
- **LEDs MUST use resistors!**
- Each output has independent configuration for:
 - >30 different lighting effects such as on/off, blinking, “fire”, pulsing, fluorescent tube sputtering/flickering, welder, random on/off and more! See Section 1.5 for the complete list with descriptions.
 - Brightness
 - Trigger via external switch, DCC switch command, LCC Event ID, or LCC fast clock time on/off
- Group outputs together for complex effects (e.g. traffic signal, TV)
- Two RJ-45 jacks for connecting to the LCC bus
- Master on/off switch input
- Optional input board (#LEIB) for connecting pushbutton or toggle switches to trigger the outputs
- Optional output test board (#LEOTB) with different colored LEDs
- Optional relay board (#LERB) for handling heavier loads such as electroluminescent signs and sound modules

1.1 Package Contents

- *Light EFX-16HC* circuit board
- Eight 1K ohm ¼ watt resistors
- 3 ft. LCC cable
- Female plug-to-terminal block adapter for DCC track power connection
- One 8” Just Plug®-compatible cable assembly to connect your own LED; additional cables are available for purchase separately (#JPC4).
- User’s Guide

1.2 Power Requirements

The *Light EFX-16HC* will operate from 9-12VAC or 12-15VDC and draws a maximum current of 2 amps. It can be powered from a suitable wall transformer such as our #WT12DC2 or from DCC track power.

Do NOT use a train power pack as a source of power. Their outputs typically have peak voltages which exceed our specs!

The wall transformer must have a barrel jack plug with dimensions 2.1mm ID and 5.5mm OD. See Section 4 for more details! When using a wall transformer take care when plugging into an available AC outlet.

Caution: children under the age of 14 should not be allowed to do this without adult supervision! Electrocutation and death could occur!

Note that some “12VAC” power sources may exceed 12V! If the input voltage exceeds 17V, all outputs will be deactivated and the blue LED will repeatedly show 3 short blinks.

1.3 Board Callouts

The *Light EFX-16HC* board is shown below with callouts for the key connectors and other items you will interact with.

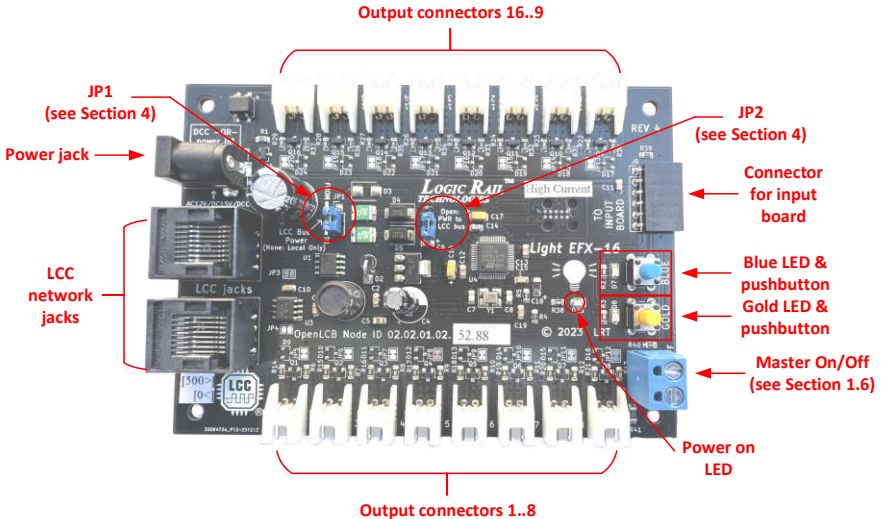

The gold LED will be on when the board is connected to LCC and the blue LED will be on when the board is connected to DCC. There are exceptions to this which you'll find in other sections of this User's Guide.

1.4 Definition of Terms

In this User’s Guide you will see the terms “on”, “off”, “activate” and “deactivate.” We will use “activate” to indicate when an output is providing the selected effect (i.e. power is provided to the connected LED(s)) whereas “deactivate” indicates when the output is not providing the effect (i.e. no power is provided). We’re using these two terms to differentiate from an effect which is turning on or off or alternating between on and off (e.g. blinking). For example,

- An output is defined to Blink; the connected LED will turn on and off while that output is activated and will stop that action when the output is deactivated.
- An output is defined to mimic a fire; the connected LED will flicker on and off while that output is activated and will stop that action when the output is deactivated.

One exception is the Master “On/Off” switch input (see Section 1.6).

1.5 Lighting Effect Definitions

The *Light EFX-16* supports many different lighting effects:

Effect name	Description
Steady On	No effect; constant light with the configured brightness.
Fade In/Out	When the output is activated it will fade in (up) to its configured brightness; when deactivated it will fade out (down) to zero brightness.
Blink, Phase A	Blink on/off every 600 ms; Phase A is the first half of the period. This could be used for the left side of a crossing signal.
Blink, Phase B	Blink on/off every 600 ms; Phase B is the second half of the period. This could be used for the right side of a crossing signal.
Pulse, Phase A	A combination of Blink and Fade On/Off; intensity ramps up and down.
Pulse, Phase B	Pulse opposite to Phase A.
Fast Blink, Phase A & B	Same as Blink but turns on/off every 250 ms
Strobe	Short flash every 2 seconds with quick ramp-up and ramp-down
Double Strobe	Two short flashes every 2 seconds with a 50 ms pause between each pair of flashes

Fire, options 1-3	Random flickering (3 different variations). Use two different variants with a red and a yellow LED to simulate an open fire.
Fusee	Simulates the appearance of a burning fusee (railroad flare). It can also be used to simulate a roadside flare used near a vehicle accident scene. Two variants are provided: one “burns” for 30 seconds while the other burns indefinitely (see Section 7.5 for usage). When first triggered, the fusee will light up brightly for an instant to suggest ignition. At the end of the burn cycle the fusee will sputter as it burns out.
Welding	Simulates the light pattern of a typical arc welder. Two different effects are provided; one intended for use with a cool white LED and one intended for use with a blue LED. Each “weld” runs for a short, but randomly variable length of time. The time between welds varies randomly between 5 and 13 seconds. See Section 7.4 for tips.
Photographer flash (modern)	Mimics a typical cellphone camera flash. Two short blips, then a high intensity flash. A second sequence occurs 5 seconds later. Repeats at a random interval.
Photographer flash (classic)	Mimics a conventional camera flash. Gives a single high intensity flash with a sharp edge then a slow ramp down. A second flash event occurs 5 seconds later. Repeats at a random interval.
Mercury Vapor Lamp	Output ramps up in intensity from off to full on over approximately 20 seconds
Fluorescent Tube (Good)	Sputtering typical of a tube when first switched on; then stays on solid.
Fluorescent Tube (Bad)	Random flickering typical of a failing tube. Two variations are provided.
Random on/off (10-300)	Output turns on at a random time between 10 seconds and 300 seconds (5 minutes) and stays on for a random duration. It then turns off and repeats at another random time and random duration.
Random on/off (2-60)	Output turns on at a random time between 2 seconds and 60 seconds (1 minute) and stays on for a random duration. It then turns off and repeats at another random time and random duration.
Bathroom light	Output turns on at a random time between 2 to 5 minutes (real time). Stays on for 10 seconds then shuts off. Initially waits a random time before first turning on so that not all outputs configured with this effect turn on simultaneously.

Rotary Beacon	Repeating cycle where brightness ramps up from 0 to ~40% then briefly goes to full brightness before ramping down from ~40% to 0.
Emergency Beacon, Phase A & B	Low light output during the off period, then a quick ramp to full brightness, then a quick ramp down. Period is ~2 Hz.
Emergency Headlight, Phase A & B	Keeps at a moderate brightness always on, then pulses at high brightness alternating on left (A) and right (B) headlight
Emergency Strobe, Phase A & B	Dark in a half period, then the other half period there are four very short flashes evenly distributed.
Emergency Strobe Alt, Phase A & B	Alternative strobe pattern. Half period is off while the other half period there are two short blinks then a long blink.
Traffic light A/B	Green, Yellow and Red outputs; see the next table for behavior; consider group A for the North-South route through an intersection and group B for the East-West route.
Traffic light A/B, Yellow (EU)	Behaves similar to the yellow phase for a “standard” traffic light but also lights up while the red is on 1 second before the light transitions to the green phase. See the second table which follows.
Traffic light A/B, Pedestrian Green (EU)	Behaves the same as Green but during the time the traffic signal would be yellow this output will blink. This is used in many EU countries. Match it with a regular Red on the same signal.
Traffic light A/B, Pedestrian Red	Behaves the same as Red but during the time the traffic signal would be yellow this output will blink. This is used in some areas of the U.S.. Match it with a regular Green for the white Walk sign on the same signal.
Chase Lights (1-6)	Each of the six outputs is a unique effect providing the chase lights you might find on a theater marquee, building sign or airport runway. When triggered together each of the six effects will turn on, one at a time, in sequence and then repeat. See Section 7.6 for tips.

Traffic light behavior

We have provided two groups of outputs so that you can create a full intersection with signals covering both routes (N-S, E-W).

U.S. Version

Time duration (secs)	Group A outputs (e.g. North-South)	Group B outputs (e.g. East-West)
1	Red	Red
11	Red	Green
3	Red	Yellow
1*	Red	Red
11	Green	Red
3	Yellow	Red

*Notice that in the table above there's a 1 second period when both output sets are RED. This reflects when the signals for both routes (North-South, East-West) are held Red briefly before changing to Green for one route (N-S OR E-W).

EU Version

Time duration (secs)	Group A outputs (e.g. North-South)	Group B outputs (e.g. East-West)
1	Red	Red Yellow
11	Red	Green
3	Red	Yellow
1	Red Yellow	Red
11	Green	Red
3	Yellow	Red

1.6 Master On/Off Switch

If you are NOT using the optional input board you can connect a single SPST (Single Pole Single Throw) switch to the two blue terminals marked MSTR ON/OFF. A connected switch will control ALL 16 outputs at once and will behave according to the input type defined for the outputs (see Section 5.2 for DCC and Section 6.5 for LCC). Care should be taken to define the same input type for all 16 outputs if this switch is used. Do NOT connect the input board if this switch is used!

2. Outputs and LED wiring

Each Just Plug®-compatible output provides a positive DC voltage (approximately equal to the voltage you provide to the board) on the lefthand pin of the connector and the negative/active low/ground on the righthand pin. The “effect” is controlled through the righthand pin. The Just Plug® cables from Woodland Scenics® have a gray wire for the anode/positive side of the LED(s) and a black wire for the cathode/negative side of the LED(s). Our cables (#JPC4) have a red wire for the anode/positive and a black wire for the cathode/negative. Cables provided by other sources may have a different color scheme so please pay close attention!

2.1 Basic LED connections

This high current version of the *Light EFX-16* differs from the standard version in that it can provide up to 250mA per output (board maximum of 1.8A). The standard version provides what is called a constant current source (approximately 20mA) and has the advantage of allowing LEDs to be connected directly without the need for a series resistor.

A series resistor is often pre-wired in the Woodland Scenics lights or included with lights from other sources. Resistors ARE REQUIRED with this high current version! For white LEDs we recommend a value of at least 1K ohm (1000 ohms) rated at ¼ watt or higher; for color LEDs we recommend at least 680 ohms rated at ½ watt or higher. The wiring scheme is shown below.

The *Light EFX-16* must only be used with LEDs and NOT incandescent bulbs no matter how small the bulbs may be!

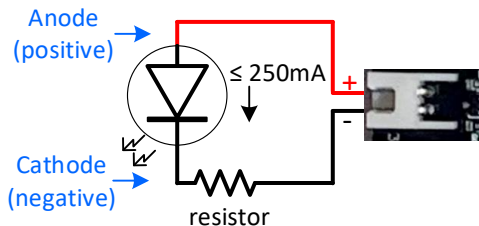

2.2 Multiple LEDs on one output

You may consider wiring multiple LEDs to each output. For example, you might want to have a multiple streetlights controlled by a single output. There are two possible ways to wire multiple LEDs: series wiring or parallel wiring. If you wire them in series it has the advantage of sharing the current through each LED and reducing both the resistor value needed as well as the current drawn from the output. The downside to series wiring is that you will be limited to the number of LEDs you can use in that series chain. The number will vary based on the turn-on voltage each LED requires. Generally speaking, red, yellow and green LEDs turn on at around 2.1 to 2.4V so you can probably wire 4 in series. White and blue LEDs typically have a turn-on voltage over 3V so you will probably be limited to 3 wired in series.

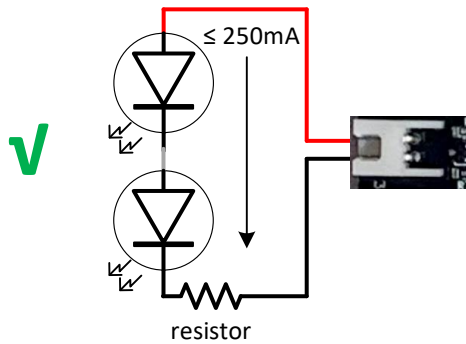

It is possible to mix LED color types when wiring them in series. An example is shown below.

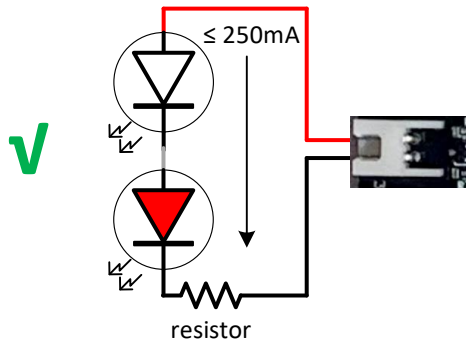

Wiring multiple LEDs in parallel is more common when using pre-wired lights (e.g. Just Plug streetlights). Each LED should have its own resistor as shown below. If you wire LEDs with different color types in parallel then you will definitely want to use one resistor per LED as shown.

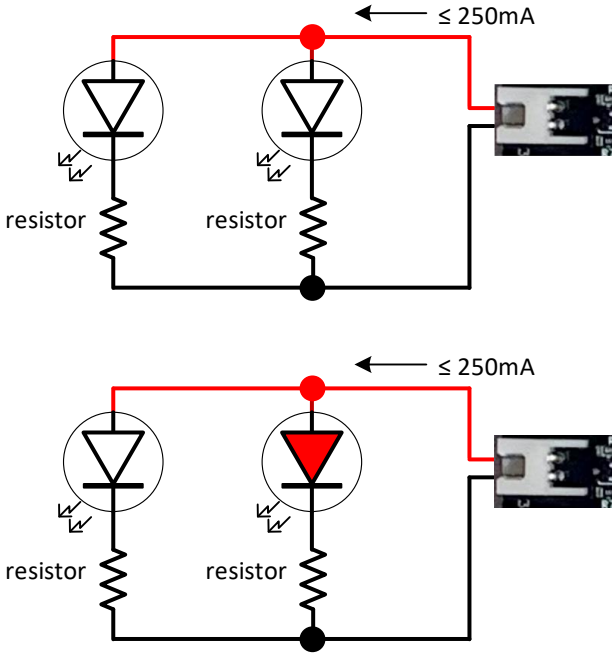

When LEDs are wired in parallel they will share the output current.

2.3 Special light situations

One of the cool effects supported by the *Light EFX-16* is an automobile traffic signal. You can configure 3 outputs to control a typical red, yellow, and green traffic signal. Commercial signals (e.g. Walthers SceneMaster products) are usually wired with a common anode/positive. As such they have 4 wires (positive common, negative red, negative yellow and negative green).

NOTE: the *Light EFX-16* can only control multi-LED lights wired with a common anode!

For ONE of the outputs on the *Light EFX-16* you will use BOTH pins on the connector. As previously described the lefthand pin on the connector is a positive DC voltage so you MUST connect the traffic signal's positive common to it. For the right hand pin you can connect ANY of the three colored wires. For the other TWO outputs you only need to use the righthand pin. In the example diagram below we are connecting the black wire (positive common) and the red wire (negative red) to one connector, the yellow wire (negative yellow) to the righthand pin on a second connector and the green wire (negative green) to the righthand pin on a third connector.

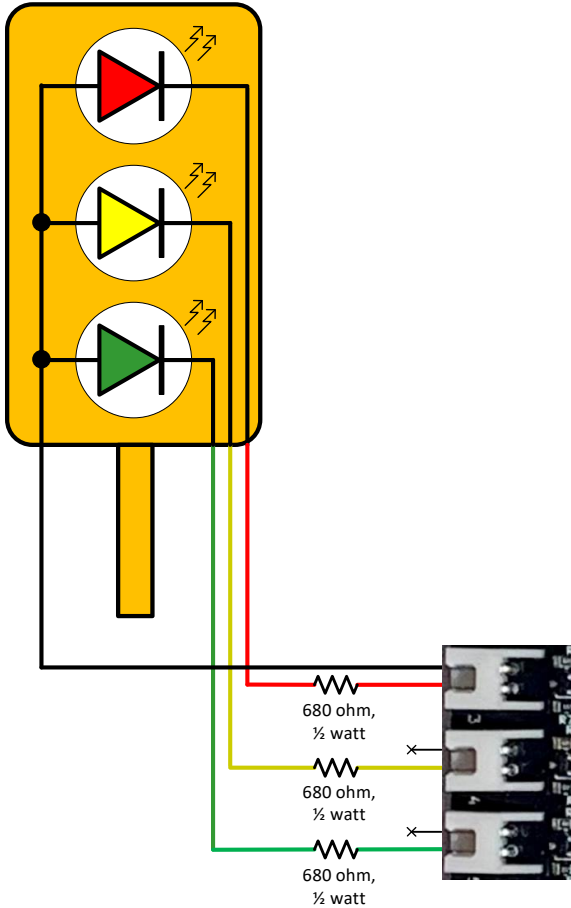

Refer to Section 7.1 for details on configuring multiple outputs for traffic signals.

3. Connecting to DCC or LCC

You must choose to either use DCC or LCC to configure the *Light EFX-16*. Once configured the board is not required to remain connected to either; you can power it independently and have effects always activated or triggered by the *Light EFX-16* input board.

Connecting DCC

To connect DCC track power to the *Light EFX-16* use the female plug-to-terminal block adapter (included!) and insert into the mating power jack on the *Light EFX-16* board. Connect your DCC track power to the terminal block; ignore the + and – markings as there is no polarity to be concerned with! See the image below.

DCC track voltage differs amongst the various manufacturers. We recommend that you use the “S/HO” or “N” scale setting if your command station or booster is configurable. In any case if the voltage exceeds 17V DC equivalent the board will not function properly (see Section 1.2).

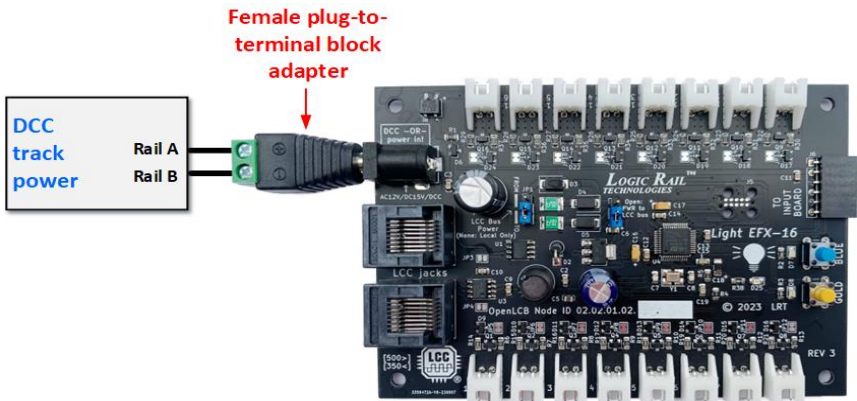

NEVER connect the *Light EFX-16HC* board to BOTH DCC and LCC at the same time. This could cause damage to your DCC and/or LCC equipment, which are NOT covered under our warranty!

Connecting LCC

Take the following steps to connect the *Light EFX-16HC* to an LCC network:

1. Make sure that the LCC network power source is OFF.
2. Plug either end of an LCC cable into either of the RJ-45 jacks on the *Light EFX-16HC* board. Make sure you hear the connector “click.”
3. Plug the other end of the LCC cable into any other LCC device. If this *Light EFX-16HC* board is the last one in the “chain” make sure you install an LCC bus terminator into the other (open) RJ-45 jack on the board.
4. Refer to Section 4 for power methods then go to Section 6 for configuring the board using JMRI PanelPro.

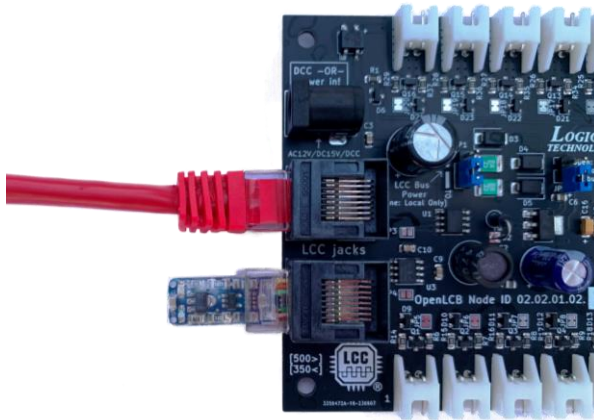

NEVER connect the *Light EFX-16HC* board to BOTH DCC and LCC at the same time. This could cause damage to your DCC and/or LCC equipment, which are NOT covered under our warranty!

4. Power methods

The *Light EFX-16HC* can be powered in 3 different ways.

- DCC track power: covered in Section 3
- Self-power: an external wall transformer plugs into the *Light EFX-16HC* and provides power TO the LCC bus through the RJ-45 jacks; depending upon the capacity of the wall transformer and the power consumed by the *Light EFX-16HC* board and its outputs the *Light EFX-16HC* could provide up to 500mA to each RJ-45 jack. No power is taken from the LCC bus. **NOTE: any power provided TO the RJ-45 jacks must be factored into the 1.8A maximum capability of this board!**
- Local power: an external wall transformer plugs into the *Light EFX-16HC* but does NOT provide power TO the LCC bus. No power is taken from the LCC bus and thus the 1.8A maximum current drawn from this board can all be consumed by the board's outputs.

There is no concern for polarity when using either the female plug-to-terminal block adapter or the barrel jack directly with a wall transformer.

NEVER connect the *Light EFX-16HC* board to BOTH DCC and LCC at the same time. This could cause damage to your DCC and/or LCC equipment, which are NOT covered under our warranty!

Refer to the orientation of the *Light EFX-16HC* board in Section 1.3. There is a two-pin jumper block (with the designation JP1) near the upper right rear of the RJ-45 jacks; there is text to the left of the jumper block which reads LCC Bus Power. There is a two-pin jumper block (with the designation JP2) to the right of JP1. The position of the blue jumper on these jumper blocks determines which power method is being used.

Power method	JP1 jumper	JP2 jumper
DCC track power	Cover any one pin	Cover both pins
Self-power (to LCC bus)	Cover both pins	Cover either pin
Local power (no power to or from LCC bus)	Cover any one pin	Cover both pins

For the cases where only one pin is covered, we recommend installing the blue shorting plug on any one of the pins on that jumper block so that you don't lose the shorting plug!

When the board has power, the green LED located below the *Light EFX-16* logo on the board will be illuminated.

5. Configuring the *Light EFX-16* using DCC

The *Light EFX-16* can be configured using DCC through Programming On the Main (POM). Some DCC manufacturers may also call this Loco Ops mode programming. Start by connecting DCC track power (NOT your programming track!) to the screw terminals on the female plug-to-terminal block adapter (included).

MAKE SURE THAT YOU DO NOT HAVE ANYTHING PLUGGED INTO EITHER OF THE RJ-45 JACKS!

Next, insert the female plug-to-terminal block adapter into the mating black socket on the *Light EFX-16* board.

Refer to your DCC system's documentation for specific steps on how to use POM. You will also need to understand if your DCC system accepts decimal values when programming Configuration Variables (CVs) or if hexadecimal values are required. Programming operations are write-only; you cannot read back values!

Once you have finished configuring the board you can either continue to power it from DCC track power OR you can provide AC or DC power through the terminal block or with a suitable wall transformer which has a plug matching the specs in Section 1.2. If you do choose to keep it connected to DCC track power please be aware of the amount of current you may be drawing from your command station or booster. Remember, a fully loaded board can draw up to 1.8A!

5.1 Addressing the Light EFX-16

To configure a specific *Light EFX-16* board you must press the board's gold button once. The board will then enter DCC loco POM mode for 60 seconds, the gold LED on the board will blink and LEDs attached to one or more of the 16 outputs will also blink. Selecting "any" loco address use POM to program it according to your DCC system's specific steps.

You should avoid using the address of a DCC locomotive already on your layout!

Note that the 60 second period RESTARTS automatically after every CV programming operation. As long as you can program a CV within 60 seconds then you effectively have 60 more seconds to program another CV. If the 60 second period expires without programming a CV the board will automatically exit loco POM mode; the gold LED will stop blinking and the light outputs will revert to their programmed effect state. You can exit POM mode before the 60 period expires by pressing the gold button again. If the 60 second period has expired and you have more CVs to program then simply press the gold button again. When you program a CV in loco POM mode any LEDs connected to the outputs will briefly light up solid then go back to flashing which indicates the board is still in POM mode. A rejected value (e.g. out of range for a particular CV) results in adjacent light outputs alternately flashing once before all outputs go back to flashing.

It is also possible to use a switch command for **remotely** entering POM mode. Once this is done you won't have to physically access the board to press the gold button. Once you have set the remote POM entry/exit address you send an accessory command (closed or thrown, it doesn't matter) to that address. The gold LED will blink and LEDs attached to one or more of the 16 outputs will also blink. As described above you'll have 60 seconds to program CVs. You can exit POM mode before the 60 seconds expires by sending another accessory command to the same address you established. If the 60 seconds expires you can repeat this step to reenter POM mode.

There are two methods for setting the remote POM entry/exit address. The easier of the two methods is to program two CVs with the board in loco POM mode:

1. Enter loco POM mode by pressing the board's gold button once.
2. Program CV 197 to the desired remote POM entry/exit address thousands-hundreds (value of 0 to 20)
3. Program CV 217 to the desired remote POM entry/exit address tens-ones (value of 0 to 99)

NOTE: the valid range for the address is 0-2044

For the second method follow these steps:

1. Press the blue button **17** times.
2. Press the gold button **once**.
3. Send a switch command (closed or thrown, it doesn't matter) to the desired address (e.g. 777). **NOTE: the valid range for the address is 0-2044**
4. That address will be stored on the *Light EFX-16* board.

5.2 Definition of Configuration Variables (CVs)

The *Light EFX-16* uses several CVs for each output. These are defined as follows:

- CV 121-136: brightness for outputs 1 to 16. Values of 1 to 100 are accepted.
- CV 141-156: effect selection for outputs 1 to 16. Values of 0 to 52 are accepted.
 - 0: None / Steady On
 - 1: Fade On/Off
 - 2: Blink Phase A
 - 3: Blink Phase B
 - 4: Pulse Phase A
 - 5: Pulse Phase B
 - 6: Fast Blink Phase A
 - 7: Fast Blink Phase B
 - 8: Strobe
 - 9: Double Strobe
 - 10: Fire 1
 - 11: Fire 2
 - 12: Fire 3
 - 13: Fusee (30 sec)
 - 14: Fusee (indef)
 - 15: Welding (White)
 - 16: Welding (Blue)
 - 17: Photographer (Modern)
 - 18: Photographer (Classic)
 - 19: Mercury Vapor Lamp
 - 20: Fluorescent Tube (Good)
 - 21: Fluorescent Tube (Bad 1)
 - 22: Fluorescent Tube (Bad 2)
 - 23: Random On/Off (10-300)
 - 24: Random On/Off (2-60)
 - 25: Bathroom
 - 26: Rotary Beacon
 - 27: Emergency Beacon A
 - 28: Emergency Beacon B
 - 29: Emergency Headlight A
 - 30: Emergency Headlight B
 - 31: Emergency Strobe A
 - 32: Emergency Strobe B

- 33: Emergency Strobe Alt A
- 34: Emergency Strobe Alt B
- 35: Traffic Light A Red
- 36: Traffic Light A Yellow
- 37: Traffic Light A Yellow (EU)
- 38: Traffic Light A Green
- 39: Traffic Light A Pedestrian Red (US)
- 40: Traffic Light A Pedestrian Green (EU)
- 41: Traffic Light B Red
- 42: Traffic Light B Yellow
- 43: Traffic Light B Yellow (EU)
- 44: Traffic Light B Green
- 45: Traffic Light B Pedestrian Red (US)
- 46: Traffic Light B Pedestrian Green (EU)
- 47: Chase Light 1
- 48: Chase Light 2
- 49: Chase Light 3
- 50: Chase Light 4
- 51: Chase Light 5
- 52: Chase Light 6
- CV 161-176: input type (**see note which follows on next page**)
 - value of 0: The physical input is a pushbutton; light output default (power-on state) is ON/ACTIVATED. DCC accessory address is enabled.
 - value of 1: The physical input is a pushbutton; light output default (power-on state) is OFF/DEACTIVATED. DCC accessory address is enabled.
 - value of 2: The physical input is a momentary pushbutton; light output default (power-on state) is OFF/DEACTIVATED. When the button is pressed it will trigger (ACTIVATE) the light output. This should be used with the Auto-Off Timer. DCC accessory address is disabled.
 - value of 3: The physical input is a toggle switch; light output is ON/ACTIVATED when the switch is closed (input is grounded) and OFF/DEACTIVATED when the switch is open. DCC accessory address is disabled.
 - value of 4: The physical input is a toggle switch; light output is OFF/DEACTIVATED when the switch is closed (input is grounded) and ON/ACTIVATED when the switch is open. DCC accessory address is disabled.
 - value of 5: this output Follows Previous output. For example, if you use this value for output 7 then it will be

activated and deactivated when output 6 is activated and deactivated. The physical input is disabled and DCC accessory address is disabled.

- CV 181-196: accessory number thousands-hundreds (value of 0 to 20)
- CV 201-216: accessory number tens-ones (value of 0 to 99)
NOTE: the valid range for the accessory number is 0-2044
- CV 221-236: Auto-Off Timer (value of 0 to 255 seconds)

This feature will make the board automatically deactivate the output after the specified number of seconds. Set to 0 (default value) to disable this feature. The timer is not re-triggerable before it has expired. Example use cases are:

- Layout visitors press a button that triggers a light effect for a certain period of time (see Section 7.2 for a specific application)
- A timed Fusee (see Section 7.5 for details)

NOTE: To have physical inputs such as push buttons or toggle switches you will need the *Light EFX-16* input board. This board plugs into the *Light EFX-16* board and provides individual input connections for all 16 lights outputs. If you are NOT using the input board then set CVs 161-176 to a value of 0 or 1 depending on whether you want the outputs to be On/Activated when power is applied or Off/Deactivated.

Here is an example for configuring one of the outputs. In this case we want output #7 to blink using Phase A with a brightness level of 50 and triggered using DCC accessory address 1026. You will program the CVs as follows (all numbers shown are in decimal form):

- CV 147 (effect selection): 2
- CV 127 (brightness): 50
- CV 167 (input type): 1
- CV 187 (accessory address number thousands-hundreds): 10
- CV 207 (accessory address number tens-ones): 26*

* Note: Some DCC system manufacturers number the accessory addresses differently than others. Depending on your DCC system, certain accessory addresses, when configured via the DCC CV numbers,

might not work as expected. An example problematic address is accessory number 511.

If you wish to restore the *Light EFX-16* board to its factory default settings you can write a value of 8 to CV 8.

5.3 Alternate Method for Configuring DCC Accessory Addresses

An alternate method to programming CVs 181-196 and 201-216 is to press the blue button 1 to 16 times to select the output. Then press the gold button once and then send a switch command (closed or thrown, it doesn't matter) to the desired accessory address. That address will be stored for the selected output. This method does not need CV programming and works on any DCC system for any accessory address.

5.4 Using JMRI DecoderPro

You can use JMRI's DecoderPro along with a suitable hardware connection (e.g. Digitrax PR4) to program the *Light EFX-16* board's CVs. Just as you would use a DCC throttle, you must use Programming on Main (POM) mode. Refer to JMRI documentation to set up the hardware connection.

Refer to the beginning of this chapter for specific steps to use POM mode.

JMRI DecoderPro version 5.8 (or later) includes a decoder definition file for the *Light EFX-16* which can be found within the Logic Rail Technologies folder (named "logicrailtech").

Be aware of the DCC track output limitations of the hardware connection you're using. For example, we have found that the Digitrax PR4, when used as a standalone programmer, limits its output current to less than 300mA regardless of the power supply connected to it; this limitation would preclude you from connecting LEDs to more than 8 outputs on the *Light EFX-16* board while programming it. Other DCC hardware solutions may not have such limits.

Once you create a New Loco using the *Light EFX-16* decoder model you will be presented with a programming window such as the one shown below. Note that there is a separate tab for each of the 16 outputs.

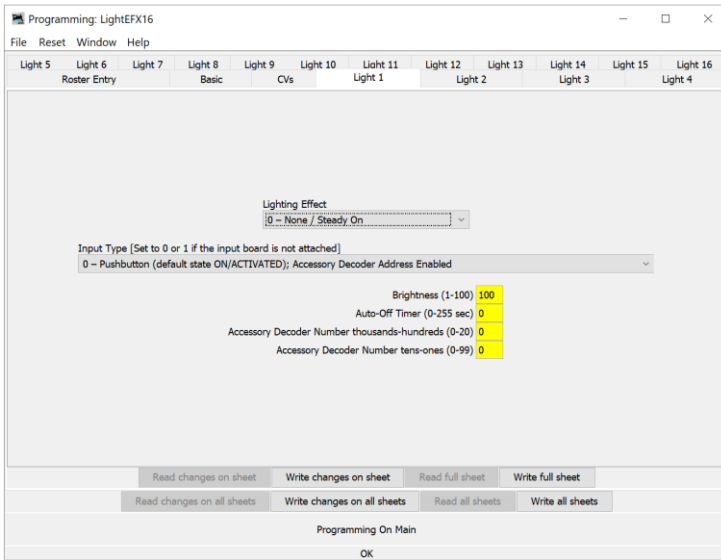

The Lighting Effect and Input Type are selected from dropdown menus. The other parameters are numeric which you will type in. Refer back to Section 1.5 for detailed definitions for the effects and Section 5.2 for more details on the Input Type and Auto-Off Timer.

Remember to press the gold button on the *Light EFX-16* board BEFORE you click on any of the Write buttons on the bottom of each panel!!! If you don't then the board will not enter POM mode!

5.5 Simple Time-based Control

You can use JMRI's DecoderPro along with a suitable hardware connection. A powerful feature of the *Light EFX-16* is the ability to have the outputs activated/deactivated based on fast clock time. This is best accomplished using LCC and a suitable fast clock time source. If you don't use LCC but have one or more of our LocoNet® Fast Clock (LNFC) products then you can use the Event Triggers feature on those modules. More details can be found in an application note available from our website.

6. Using JMRI PanelPro + LCC with the *Light EFX-16*

The power of LCC is really apparent when you utilize JMRI (Java Model Railroad Interface). This User's Guide assumes you are familiar with JMRI and PanelPro. There are MANY online resources and tutorials to guide you through the JMRI installation process and familiarize yourself with its PanelPro application. Start by going to <https://www.jmri.org/>.

Once you have PanelPro running and connected to the LCC bus through a device such as the LCC Buffer-USB from RR-CirKits (<https://www.rr-cirkits.com/>) then you're ready to discover all the cool things you can do with your *Light EFX-16* and other LCC devices.

You will need to provide power directly to the *Light EFX-16* board through its barrel jack AND set its power configuration jumpers as detailed in Section 4.

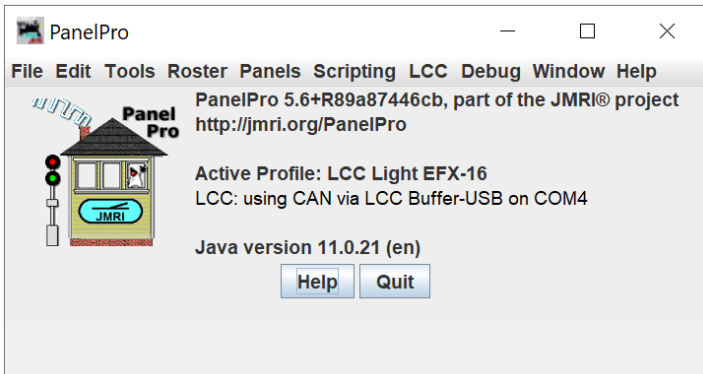

From the PanelPro main window click on LCC (or whatever you have named the LCC-related connection; OpenLCB might be another name you chose) then click on Configure Nodes. A new window will open showing the OpenLCB Network Tree.

6.1 OpenLCB Network Tree

In the OpenLCB Network Tree you will find your *Light EFX-16* module (or modules if you have more than one).



Single-click the symbol to the left of the Light EFX-16 folder to expand it. This could be a “+” sign or other symbol based on the GUI you have selected under Display in your PanelPro Preferences.

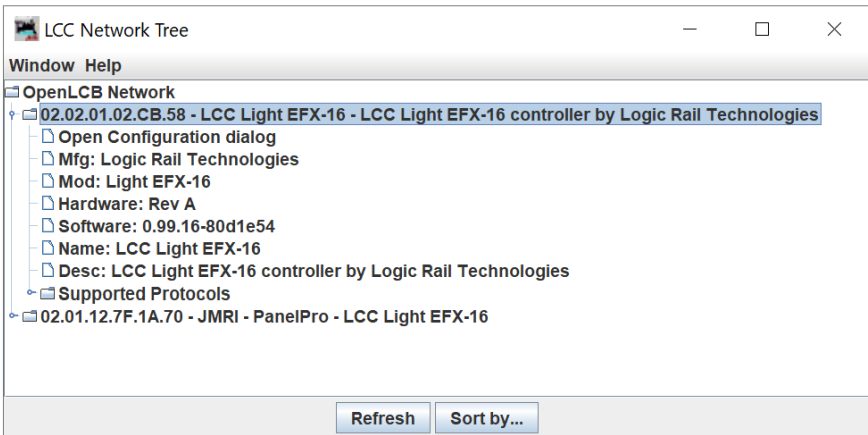

Now single click on “Open Configuration dialog” which will launch another window.

6.2 Light EFX-16 Identification and Naming

The first part of the Configuration dialog (commonly called the CDI) is the device identification information and the naming options. In the first part you will find the hardware version and current module software (firmware) version.

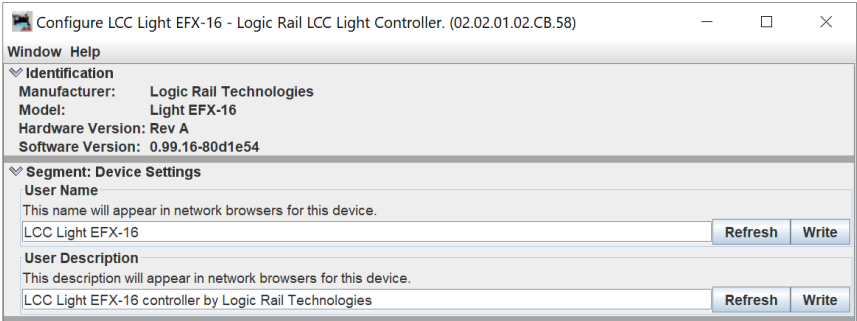

Before you make ANY changes to the CDI we strongly recommend that you back up the default state. This is easily accomplished by clicking on the BACKUP button at the bottom of the CDI window. Set the filename to something meaningful!

In the Device Settings section you will find entries for the User Name and User Description. You can change these values if you wish. For example, if you have a *Light EFX-16* board dedicated to a city scene you may want to name it accordingly to differentiate it from other *Light EFX-16* boards on your layout.

6.3 Configuration: name, brightness, and effect

The next part of the CDI allows you to configure all aspects of each output. This includes naming the output, setting the brightness, selecting an effect, and grouping multiple outputs together. These settings are retained once power is removed from the board.

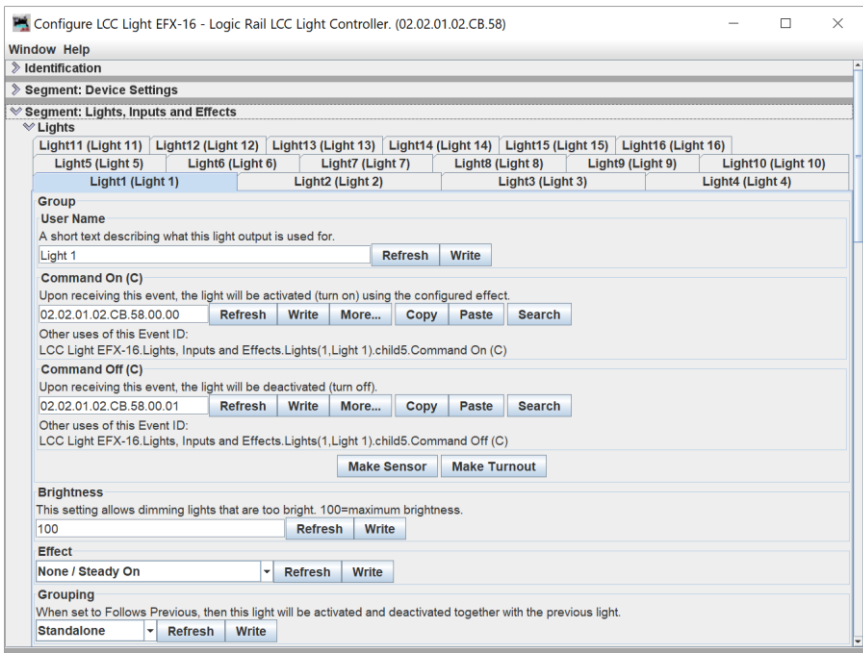

Most of the fields should be self-explanatory but there is a brief text description below each field name.

User Name

We recommend you change the name of each output to something more meaningful than just “Light X.” For example, Light 1 may be connected to the streetlight on Main Street. Simply type in your desired name then click on the Write button. You will see that the name is now shown in parenthesis next to Light 1. The output number is retained so that you don’t lose track of which physical connector on the board this is assigned to!

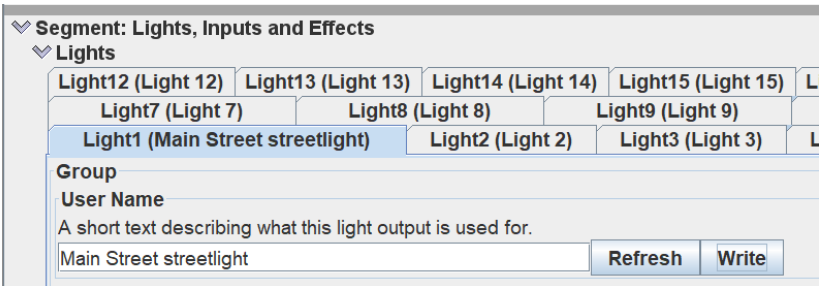

Command On (C) and Command Off (C)

These fields can be used for activating an output (Command On) or deactivating it (Command Off) based on an Event ID coming from another LCC device. For example, you may have hardware switches connected to a Tower LCC board from RR-CirKits. You can also create a JMRI Turnout or Sensor to activate/deactivate this output by clicking the respective button here. Another example is to use time-based events from an LCC fast clock source such as our own or the one supported by the TCS CS-105 command station. Refer to the appropriate product documentation for details on defining the event ID. In our LCC fast clock documentation this is Section 6.6.

Brightness

The full brightness level for the output can be set between 1-100. This level is the maximum the output will achieve regardless of the effect. For example, if the output is configured as “Fade On/Off” the brightness value is what the output will reach at the end of the Fade On effect. Different colors and types of LEDs will have different nominal brightness levels. White LEDs may be significantly brighter than a colored LED with both provided 20mA of current from the *Light EFX-16* outputs. You may consider configuring lower brightness levels for any output connected to a white LED.

Effect

A drop-down menu is used to select the effect for this output. Refer back to Section 1.5 for a description of the various effects.

Grouping

This setting allows you to have consecutive outputs activated and deactivated together. For example, you might have a building with different lights (and even different effects) which you want to use a single control function (physical switch, event, time-based, etc.) for. If you configure an output as **Follows Previous** it will follow the activate/deactivate state of the previous output. For example, if you configure output 11 as **Follows Previous** then whenever output 10 is activated output 11 will also be activated. When output 10 is deactivated output 11 will also be deactivated.

6.4 Configuration: DCC Accessory Address, Auto-Off Timer

DCC Accessory Address

Here you can specify a DCC accessory address to toggle this output between activated and deactivated. Acceptable values are 1-2044. If you wish to disable this feature then set the address to 0. Note that the default value for all 16 outputs is 99. You could consider this as a “master switch” to activate/deactivate all outputs simultaneously. This configuration setting is relevant only if you intend to later remove the board from LCC and operate with the DCC plug.

DCC Address		
Accessory decoder address to toggle this light with DCC. 1-2047, or set to 0 to disable.		
99	Refresh	Write
Auto-Off Timer		
After this many seconds, the light will turn off automatically. Set to 0 to disable. The timer is not re-triggerable. Refer to the User's Guide for more details and example usage.		
0	Refresh	Write

Auto-Off Timer

When configured, this feature will make the board automatically deactivate the output after the specified number of seconds. The timer is not re-triggerable before it has expired. If set to 0 this feature is disabled. The upper limit for the value you can enter using LCC is 65535 seconds which is 18 hours, 12 minutes, and 15 seconds!!!

NOTE: if you program a value > 255 seconds using LCC, disconnect it from LCC and subsequently attach the board to DCC that Auto-Off Timer value will be in effect. However, if you reprogram that value with DCC then you will be limited to 255 seconds (see CV 221-236 in Section 5.2).

Example use cases are:

- Layout visitors press a button that triggers a light effect for a certain period of time (see Section 7.2 for a specific application)
- A timed Fusee (see Section 7.5 for details)

6.5 Configuration: input behavior

The next set of fields is used to configure the hardware inputs if you have the *Light EFX-16* input board attached. Even if you do not attach the input board you may wish to configure the default state of the outputs through the Button Type setting.

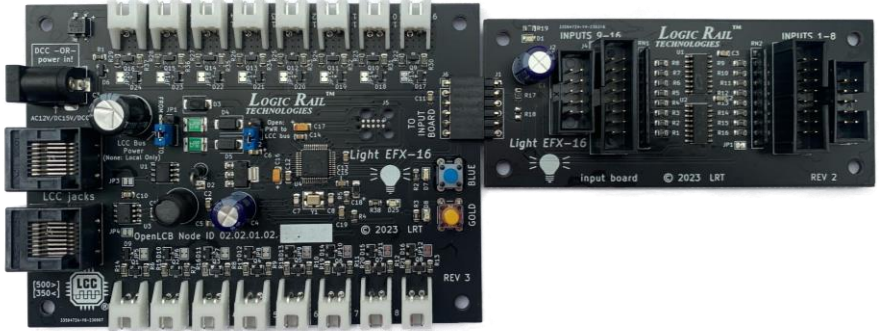

Input
Configures the corresponding input line if the input board is attached.

User Name
A short text describing what this button input is used for.
Light 1 Input

Control Light
Should this button control the matching light output? If set to Disengaged, then the Button Input can be used as a generic purpose input button.

Button Type
Select what mechanical type of control is connected to this input line.
Pushbutton (default On)

Active (P)
This event will be produced when the input is turned on.
02.02.01.02.CB.58.00.02
Other uses of this Event ID:
LCC Light EFX-16.Lights, Inputs and Effects.Lights(1,Main Street streetlight).Input.Active (P)

Inactive (P)
This event will be produced when the input is turned off.
02.02.01.02.CB.58.00.03
Other uses of this Event ID:
LCC Light EFX-16.Lights, Inputs and Effects.Lights(1,Main Street streetlight).Input.Inactive (P)

Control Light

For each light you would typically select **Enabled** so that the corresponding line on the *Light EFX-16* input board would be used to activate and deactivate the output. However, if you select **Disengaged** then this input line could be used for other LCC-related tasks (e.g. throw a turnout).

Button Type

The dropdown menu gives you a choice of the type of hardware switch you're connecting to this input line and the behavior you want.

Pushbutton (default On)	Light output default (power-on state) is ON/ACTIVATED.
Pushbutton (default Off)	Light output default (power-on state) is OFF/DEACTIVATED.
Pushbutton (trigger only)	Light output default (power-on state) is OFF/DEACTIVATED. When the button is pressed it will trigger (ACTIVATE) the light output. This should be used with the Auto-Off Timer. Repeat presses of the pushbutton, if the effect is already activated and the Auto-Off Timer has not expired, will be ignored.
Toggle Switch	Light output is ON/ACTIVATED when the switch is closed (input is grounded) and OFF/DEACTIVATED when the switch is open.
Toggle Switch Inverted	Light output is OFF/DEACTIVATED when the switch is closed (input is grounded) and ON/ACTIVATED when the switch is open.

6.6 Extra Commands

The Extra Commands section configures a variety of features and use-cases for controlling the light output via LCC protocols:

- You might need more than just one event to activate or deactivate the light. For example, beyond individual light control, you can configure a single event to activate all the lights on the layout (a "nightfall" switch).
- You can configure three events on one output for activate, deactivate and blink. For example, this can be helpful for railroad signals. Driving signals by aspect is also possible by configuring the aspect event IDs as extra commands.
- You can configure one or more time intervals according to the fast clock to activate and deactivate the light. For example, activate the street lights during the night, or activate a shop light from 6pm to 10pm and 5am to 7am.
- You can configure an event or a fast clock time to change the brightness of the output or fade it in or out. This could be helpful when controlling RGB lighting.

NOTE: For these triggers to function you MUST configure the Button Type (see Section 6.5) to either of the Pushbutton options or set the Control Light type to Disengaged.

LCC command on/off, Alt Action on/off, DCC accessory command (on/off) and fast clock based on/off are ignored when the Button Type is Toggle Switch or Toggle Switch Inverted.

The time trigger is an easy way to set the event ID to a fast clock time event, but the two triggers act independently. As such you can create an Event-based Trigger and Time Trigger for the same action. The importance of specifying the time comes if you rewind the clock or jump it forward. The Time Triggers will be applied according to the time of day.

Extra Commands
Configuring extra commands allows setting up light scenes, signal aspects that are triggered with a single event, alternate effects, or time-based activation of the output.

Command1 | Command2 | Command3 | Command4 | Command5 | Command6

Trigger (C)
Receiving this event will trigger this action.
02.02.01.02.CB.58.00.04 Refresh Write More... Copy Paste Search

Other uses of this Event ID:
LCC Light EFX-16.Lights, Inputs and Effects.Lights(1,Main Street streetlight).Extra Commands(1).Trigger (C)

Time Trigger
Set a time to trigger this action based on the fast clock. Currently only 24-hour time is accepted, like '8:13' or '17:58'.
Refresh Write

Action
What should the light output do upon this trigger.
Disabled Refresh Write

Parameter
Adjusts specifics of certain actions.
- For "Set Brightness", this is the desired brightness value (0 to 100).
- For "Fade In/Out", this is the length of the fade, in 1/10th of seconds (e.g. value of 20 means two seconds long fade).
0 Refresh Write

Action

With this dropdown menu you select the behavior of the output when that event or time occurs. Refer to Section 7.7 for tips on how to configure grade crossing signals using current-sensing detectors.

Parameter

This field is specific to the Action you select:

- If the Action selected is "Set Brightness" then enter a value of 1 - 100. If you leave it as 0 it will set the brightness to 100.
- If the Action selected is "Fade On" or "Fade Off" the parameter entered is a length of time in tenths of seconds. For example, a value of 10 is 1 second, a value of 25 is 2.5 seconds, etc.

6.7 Global configuration

If you plan to disconnect the *Light EFX-16* board from LCC and connect it to DCC (e.g. for future configuration changes) you can set a DCC Accessory Address to enter Programming on the Main (POM) mode remotely (i.e. you won't need physical access to the board).



Global configuration
These settings apply to the entire device.

DCC configuration
These settings are only relevant when the device is used in DCC mode.

DCC Address to Trigger Programming
When this accessory is toggled, the board will go into POM programming mode for 60 seconds. This is equivalent to pressing the Gold button on the board; useful when reaching the physical buttons is difficult. Set to 0 to disable.

0

6.8 Measurements

This section provides diagnostic information for this *Light EFX-16* board. The Input Voltage is the voltage going into the LED output circuitry (1000 millivolts = 1 volt). This value is directly related to the voltage you are supplying to the board and must not exceed 17V (see Section 1.2). The Temperature value should not be a concern unless it's over 85°C!

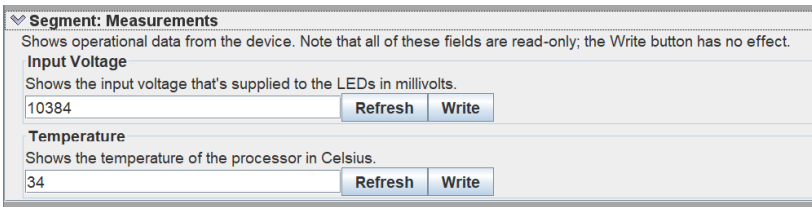

Segment: Measurements
Shows operational data from the device. Note that all of these fields are read-only; the Write button has no effect.

Input Voltage
Shows the input voltage that's supplied to the LEDs in millivolts.

10384

Temperature
Shows the temperature of the processor in Celsius.

34

6.9 Restore to Factory Defaults

JMRI PanelPro version 5.0 or later allows you to restore the *Light EFX-16* board to its factory default settings. On the bottom of the CDI window click on "More..." then select Factory Reset. You'll be given the option to make a Backup of the CDI. After that you'll be prompted to confirm the reset action.

7. Special light examples

Below are a few examples of special light configurations you may wish to use. For each example the ability to program via DCC and LCC or LCC only is specified.

7.1 Traffic signals (DCC or LCC)

You can configure a typical traffic intersection by using Group A for one route (e.g. North-South) and using Group B for the other route (e.g. East West). Here's an example using Lights 1-6:

- Light 1: Traffic Light A Red (connect to N/S signal red LED)
- Light 2: Traffic Light A Yellow (connect to N/S signal yellow LED)
- Light 3: Traffic Light A Green (connect to N/S signal green LED)
- Light 4: Traffic Light B Red (connect to E/W signal red LED)
- Light 5: Traffic Light B Yellow (connect to E/W signal yellow LED)
- Light 6: Traffic Light B Green (connect to E/W signal green LED)

Also, for Light 1 set its Grouping to Standalone then for Lights 2-6 set their Grouping to Follows Previous. This way you can use a single trigger (e.g. toggle switch) to activate/deactivate all traffic signal-related outputs.

In some towns the traffic signals behave differently late at night. For example, you could configure an Extra Command to turn the traffic lights OFF at 22:00 (10pm), a second Extra Command to turn them ON at 05:00 (5am), and a third Extra Command for just the red (or yellow) lights to start blinking at 22:01 (10:01pm).

7.2 Photographer flash (DCC or LCC)

Here are the steps to set up the photographer flash effect triggered by a pushbutton on the edge of the layout:

- Choose the Photographer (Modern) or Photographer (Classic) effect
- As described in Section 1.4 the Photographer effects produce two flash events each time it is triggered. If you only want to have a single flash each time the pushbutton is pressed then set the Auto-Off Timer to 3; otherwise, set it to 7.
- Set the Button Type to Pushbutton (trigger only)

If you want a model railfan to take a photo each time a train passes by you can use an LCC-connected block occupancy detector. To set this up:

- Use an Extra Command with the Action set to "Turn On" and configure the Block Occupied Event ID as the Trigger.

7.3 TV simulation (DCC or LCC)

There are different ways you can simulate the changing screen of a color TV viewed indirectly (e.g. in a room with a frosted window). One way to do this is with RGB (Red/Green/Blue) LEDs. This could be a single LED (which MUST have a common anode/positive lead similar to the traffic signal detailed in Section 2.3) or individual red, green and blue LEDs. One source for a 5mm diameter single lens RGB LED is:

<https://www.amazon.com/Common-Diffused-Tri-Color-Envistia-Mall/dp/B07PXZD2DS>.

Try the following configuration using Lights 14-16:

- Light 14: Fire 3 (connect to red LED)
- Light 15: Fade In/Out (connect to green LED)
- Light 16: Pulse A (connect to blue LED)

Also, for Light 14 set its Grouping to Standalone then for Lights 15 and 16 set their Grouping to Follows Previous. This way you can use a single trigger (e.g. time-based trigger using LCC or just a toggle switch) to activate/deactivate the TV.

7.4 Welding (DCC or LCC)

There are two effects related to the simulation of a typical arc welder. Minimally we recommend that you use a cool white LED and choose the Welder – White effect. Ideally you should also include a blue LED and choose the Welder – Blue effect for it. The welder effect is best viewed in an indirect manner (i.e. not viewing the LED(s) straight on). You can achieve this by placing the LED(s) underneath the object being welded (e.g. an automobile). You can also place the LED(s) behind frosted glass inside a building or open shop door.

7.5 Fusee (DCC or LCC)

As described in Section 1.5 two different fusee effects are available. One has a fixed “burn time” of 30 seconds. The other one has an infinite burn time which can be configured to burn for a prototypical 10 minutes using the Auto-Off Timer feature. For example, if you’re running a 4:1 fast clock then 10 minutes in “fast time” would take 2.5 minutes (150 seconds) of “real time.” As such you would set the Auto-Off Timer to 150. Regardless of which fusee effect you select you should use the Pushbutton (trigger only) input type.

You can use any LED to represent the physical fusee. Real fusees are typically red though some railroads had yellow ones. We offer realistic looking (in our opinion!) fusees (~0.065" diameter x ~0.25" long) in red (#F-1) and yellow (#F-1Y).

7.6 Chase lights (DCC or LCC)

There are six unique effects to implement the chase lights you might find on a theater marquee, building sign, road construction cones or airport runway. When triggered together each of the six effects will turn on, one at a time, in sequence and then repeat. You will need to use a single trigger for all lights. For example, let's assume you're going to use Lights 1 – 6. Set the Grouping for Light 1 to Standalone then set the Grouping for Lights 2 – 6 to Follows Previous. A typical marquee or sign will have multiple lights around it with them grouped together. Here is an example layout using 4 LEDs per chase effect:

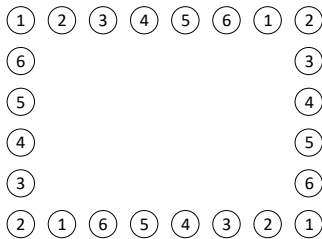

As described in Section 2.2 you can use multiple LEDs connected to a single output. For the aforementioned example you will likely need to wire the LEDs in parallel. Using the SAME type of LED wired in parallel to a given output they will share the current equally (~5mA in our example). If that yields an unacceptable brightness for you then you can reduce the number of LEDs per output to 2 AND then use another group of six outputs for the remaining LEDs. For example, you can use Lights 7-12 and configure them the same way Lights 1-6 are configured. You will also need to tie the same trigger to Light 7 as you used for Light 1.

After you have completed the configuration of your chase lights you will need to synchronize them. You can either use the switch/button, if applicable, to turn them all off and on again or simply cycle the power connected to the *Light EFX-16* board.

7.7 Grade crossing logic (LCC only)

A large, horizontal red brushstroke graphic with a textured, paint-like appearance. The stroke is centered on the page and serves as a background for the text.

COMING SOON

8. Mounting the *Light EFX-16*

The *Light EFX-16* can be mounted to a non-metallic surface anywhere it is convenient using the four mounting holes provided near the corners of the board. The holes will accept #4 screws; do not enlarge the holes or over tighten the screws (flexing the board) as damage to the circuit board can result and your warranty will be voided! We recommend that you use plastic or nylon standoffs (0.25” or taller) to facilitate easier removal of the LCC cable when necessary.

9. Updating the firmware

Any updates to the *Light EFX-16* firmware will be posted on our website. The only way to update the firmware yourself is through the LCC bus. If you are not using LCC but wish to have your *Light EFX-16* updated to the latest firmware please contact us; we can update your board at a minimal cost.

For LCC users connect your board to your PC (review Section 6) and fire up JMRI PanelPro. On the main window click on LCC then click on Firmware Update. Select the firmware update file (downloaded to your PC from our website) then select the *Light EFX-16* module you wish to update. Click on Load to perform the update.

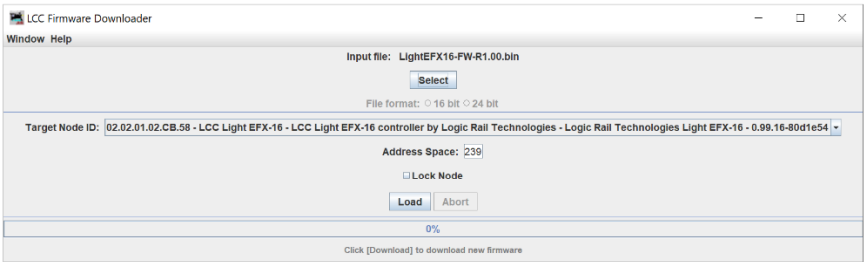

If the board is ever in a “locked up” state you can force it into “bootloader only” mode. This is done by holding down the Gold button when power is turned on to the board. The blue LED will flash 5 times indicating that it’s ready for firmware to be loaded. If the firmware is damaged by an incomplete or incorrect load, then the board will come up in bootloader mode and the blue LED will flash 4 times. A new firmware download may then be started to repair the firmware.

10. Warranty, Repair and Troubleshooting

10.1 Warranty

This product is warranted to be free from defects in materials or workmanship for a period of one year from the date of purchase. The product must be returned to Logic Rail Technologies in satisfactory condition. This warranty covers all defects incurred during normal use of this product. This warranty is void under the following conditions:

1. If damage to the product results from mishandling, abuse or exceeding input power limits. **This includes connecting it to both DCC and LCC buses at the same time!**
2. If the product has been altered in any way not previously authorized or approved by Logic Rail Technologies.

Requests for warranty service must include a dated proof of purchase, a written description of the problem, and return shipping and handling (\$10.00 inside U.S./\$20.00 outside U.S. - U.S. funds only). Except as written above, no other warranty or guarantee, either expressed or implied by any other person, firm or corporation, applies to this product.

Logic Rail Technologies reserves the right to make changes in design and specifications, and/or to make additions or improvements in its products without imposing any obligations upon itself to install these changes, additions or improvements on products previously manufactured.

10.2 Repair

The *Light EFX-16* contains no end-user serviceable parts. If you believe your *Light EFX-16* needs repair please contact Logic Rail Technologies prior to returning it. Logic Rail Technologies reserves the right to repair or replace a defective product. Products that have voided the warranty or are out of warranty will be repaired at fair and reasonable rates.

10.3 Troubleshooting

The blue and gold LEDs on the *Light EFX-16* board indicate various conditions.

Condition	Blue LED	Gold LED	Action to take
LCC connected	Off	On	n/a
DCC connected	On	Off	n/a
External power	1 blink when power is first applied	Off	n/a
Overvoltage (input voltage is >17V)	3 short blinks (repeating)	n/a	Use a lower voltage power source
Firmware is corrupted	4 blinks (repeating)	n/a	See Section 9
Awaiting firmware update	5 blinks (repeating)	n/a	See Section 9
Entered DCC loco POM mode	n/a	blinking	See Section 5.1

11. Technical Support

Please contact us via phone or email (details on the cover page of this document).

If you're using the board with LCC you may also want to subscribe to and monitor the Layout Command Control user group on groups.io (<https://groups.io/g/layoutcommandcontrol/>).